

Disc brake DBF 145

dimensions and technical data

edition 05/2023 | EN
page 1 / 1

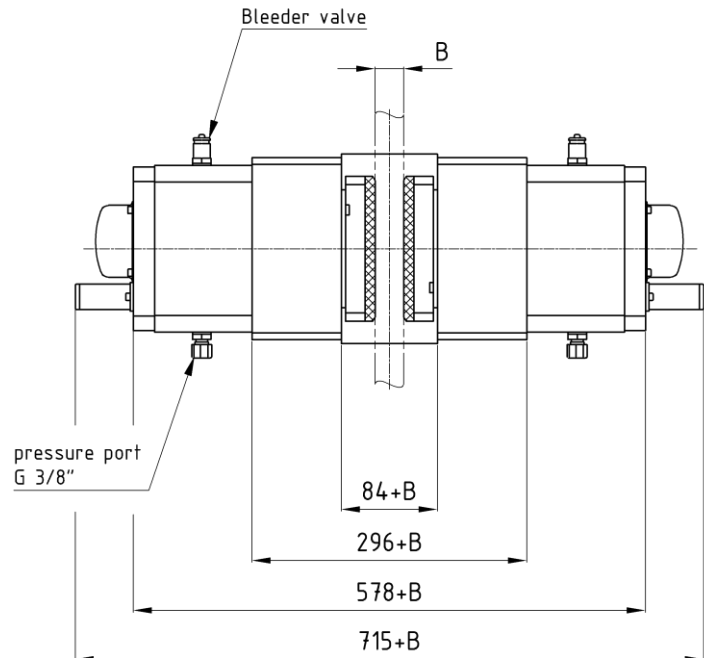
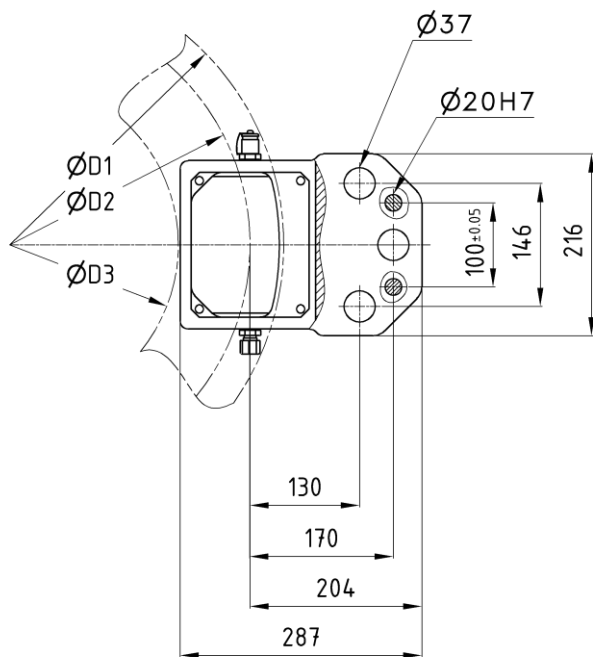

Order example: DBF 145.X - D1 x B

dimensions in [mm]

Technical data

Brake torque [kNm]					
$M_{Br} = F_A * (D2 / 1000) * \mu$					
Friction coefficient $\mu = 0,4$					
Clamp force F_A [kN] ¹⁾					
Air gap	1 mm	2 mm	3 mm	Pressure [bar]	M_A ²⁾ [Nm]
DBF 145.1	75	70	65	120	8.8 - 2500
DBF 145.2	85	80	75	130	8.8 - 2700
DBF 145.3	94	90	86	140	8.8 - 2900
DBF 145.4	104	100	96	150	8.8 - 3100
DBF 145.5	115	110	105	180	10.9 - 3300
DBF 145.6	130	125	120	200	10.9 - 3600
DBF 145.7	155	145	135	240	10.9 - 3900
Brake disc					
Brake disc diameter D1				min. 650 mm	
Friction diameter D2				D1 - 80 mm	
Hub diameter D3				D1 - 250 mm	
Brake disc thickness B				min. 25 mm	

Operational data	
Release time ³⁾	1 - 2,5 s
Theoretical close time ⁴⁾	ca. 0,2 s
Pad surface	160 cm ²
Oil volume	0,24 l
Oil volume at working stroke	0,04 l
Hydraulic connection	G 3/8" / pipe Ø12 x 1,5
Operating temperature	-20°C bis +60°C
Screw size / strength	M36 - 8.8 / 10.9
Weight without mounting bracket	177 kg

- Available with mounting bracket and assembled hydraulic power unit, filled and bled as „plug and play“- version.
- Inductive proximity switch for monitoring brake open position as standard.
- optional: Inductive proximity switch for monitoring Air gap and / or brake closed position.

1) The clamp force can vary between 5%.

2) Screw tightening torque is specified for ungreased thread. The usage of screws and nuts without surface treatment is recommended.

3) The brake release time depends strongly on the used hydraulic power unit.

4) The theoretical close time can only be achieved with the correct size of the hydraulic pipe.

subject to change without notice