

# Disc brake DBF 170 S

## dimensions and technical data

edition 05/2023 | EN  
page 1 / 1

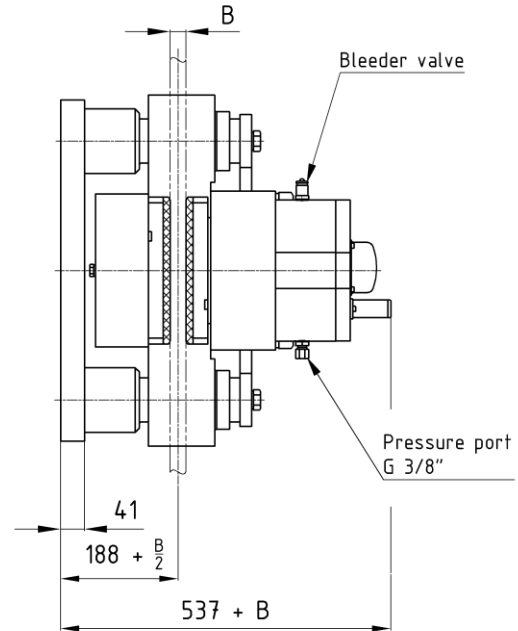
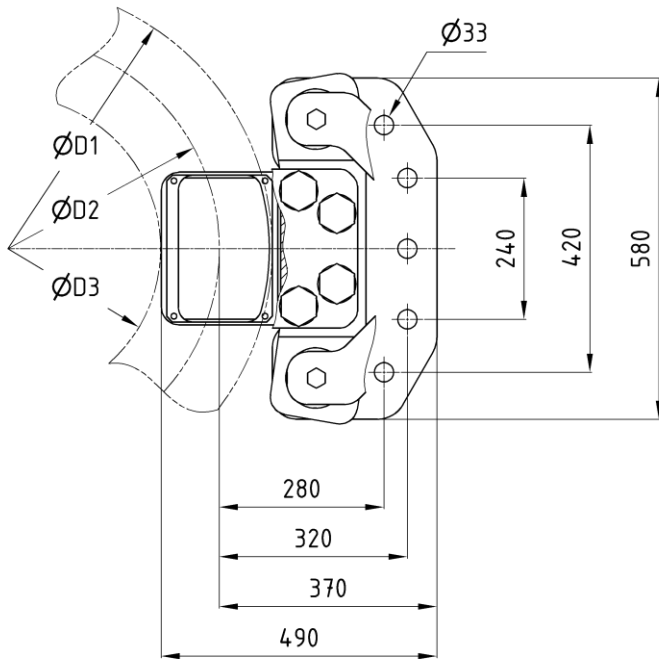

Order example: DBF 170.x S - D1 x B

dimensions in [mm]

### Technical data

Braking torque [kNm]					
$M_{Br} = F_A * (D2 / 1000) * \mu$					
Friction coefficient $\mu = 0,4$					
Clamp force $F_A$ [kN] <sup>1)</sup>					
Air gap	1 mm	2 mm	3 mm	Pressure [bar]	$M_A$ <sup>2)</sup> [Nm]
DBF 170.1 S	150	130	110	170	1200
DBF 170.2 S	170	150	130	190	1200
DBF 170.3 S	190	170	150	210	1200
DBF 170.4 S	210	190	170	230	1200
Brake disc					
Brake disc diameter D1			min 800 mm		
Friction diameter D2			D1 - 180 mm		
Hub diameter D3			D1 - 430 mm		
Brake disc thickness B			min 25 mm		

Operational data	
Release time <sup>3)</sup>	1 - 2,5 s
Theoretical close time <sup>4)</sup>	ca. 0,2 s
Pad surface	366 cm <sup>2</sup>
Oil volume	0,20 l
Oil volume at working stroke	0,03 l
Hydraulic connection	G 3/8" / pipe Ø12 x 1,5
Operating temperature	-20°C bis +60°C
Screw size / strength	M30 - 8.8
Weight without mounting bracket	358 kg

- Axial clearance of  $\pm 15$  mm can be compensated.
- Available with mounting bracket and assembled hydraulic power unit, filled and bled as „plug and play“- version.
- Inductive proximity switch for monitoring brake open position as standard.
- optional: Inductive proximity switch for monitoring Air gap and / or brake closed position.

1) The clamp force can vary between 5%.

2) Screw tightening torque is specified for ungreased thread. The usage of screws and nuts without surface treatment is recommended.

3) The brake release time depends strongly on the used hydraulic power unit.

4) The theoretical close time can only be achieved with the correct size of the hydraulic pipe.