

Disc brake DBF 170

dimensions and technical data

edition 05/2023 | EN
page 1 / 1

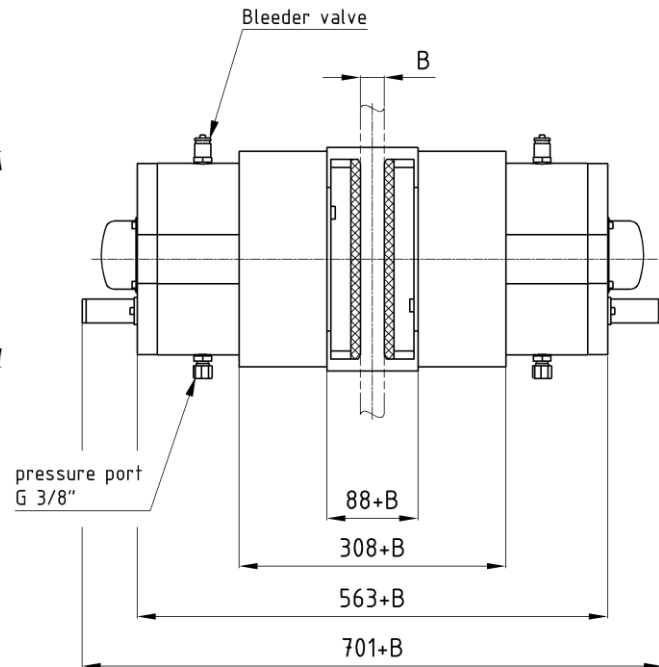
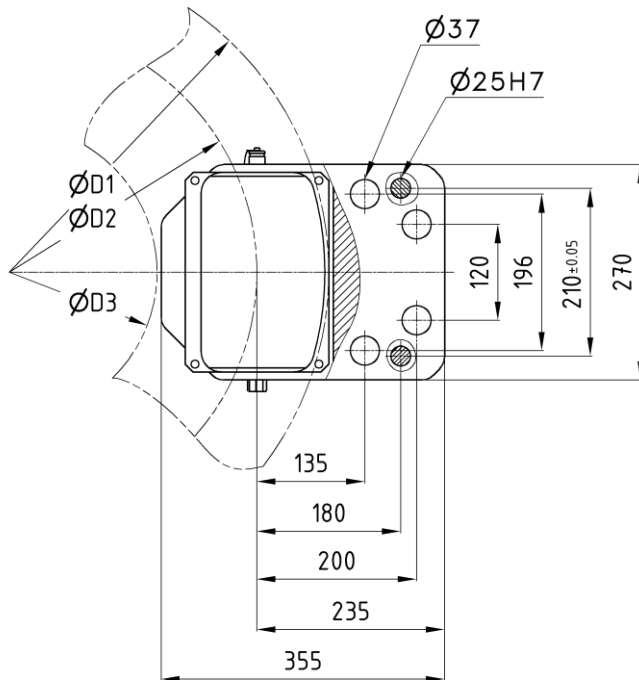

Order example: DBF 170.X - D1 x B

dimensions in [mm]

Technical data

Braking torque [kNm]					
$M_{Br} = F_A * (D2 / 1000) * \mu$					
Friction coefficient $\mu = 0,4$					
Clamp force F_A [kN] ¹⁾					
Air gap	1 mm	2 mm	3 mm	Pressure [bar]	M_A ²⁾ [Nm]
DBF 170.1	150	130	110	170	8.8 - 2300
DBF 170.2	170	150	130	190	8.8 - 2600
DBF 170.3	190	170	150	210	10.9 - 3000
DBF 170.4	210	190	170	230	10.9 - 3300
Brake disc					
Brake disc diameter D1			min. 800 mm		
Friction diameter D2			D1 - 180 mm		
Hub diameter D3			D1 - 430 mm		
Brake disc thickness B			min. 25 mm		

Operational data	
Release time ³⁾	1 - 2,5 s
Theoretical close time ⁴⁾	ca. 0,2 s
Pad surface	366 cm ²
Oil volume	0,39 l
Oil volume at working stroke	0,06 l
Hydraulic connection	G 3/8" / pipe Ø12 x 1,5
Operating temperature	-20°C bis +60°C
Screw size / strength	M36 - 8.8 / 10.9
Weight without mounting bracket	250 kg

- Available with mounting bracket and assembled hydraulic power unit, filled and bled as „plug and play“- version.
- Inductive proximity switch for monitoring brake open position as standard.
- optional: Inductive proximity switch for monitoring Air gap and / or brake closed position.

1) The clamp force can vary between 5%.
 2) Screw tightening torque is specified for ungreased thread. The usage of screws and nuts without surface treatment is recommended.
 3) The brake release time depends strongly on the used hydraulic power unit.
 4) The theoretical close time can only be achieved with the correct size of the hydraulic pipe..