

Brake drum according to DIN 15431 with center web

edition 06/2022 | EN
page 1 / 1

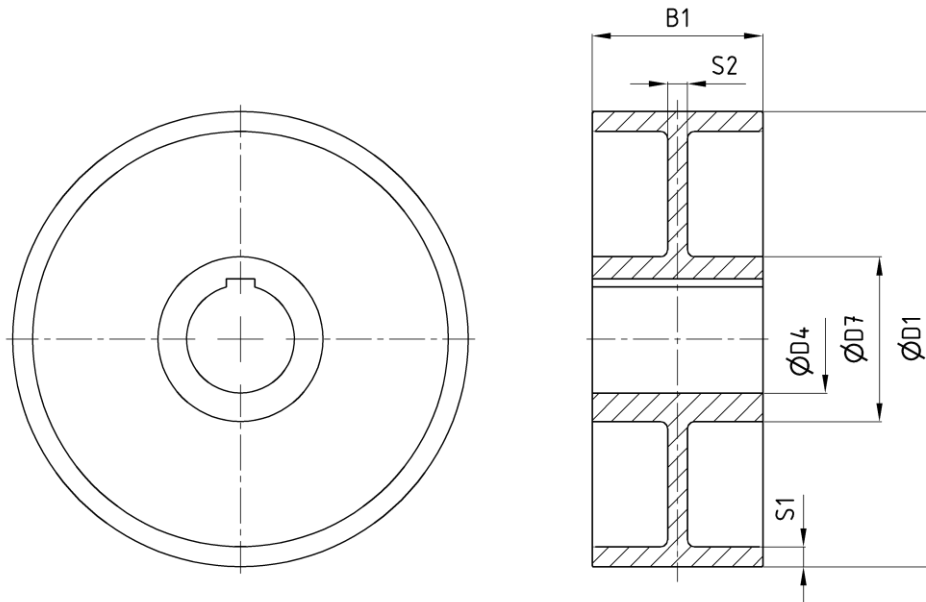

Order example: brake drum NG - D4H7P1 - dy ¹⁾

dimensions in [mm]

Technical data

n _{max} ²⁾ [1/min]	D1	B1	D4 ³⁾		D7	S1	S2	J _{rot} ⁴⁾ [kgm ²]	m ⁴⁾ [kg]
			min	max					
3000	200	75	26	55	80	12	12	0,048	8,7
3000	250	95	30	68	100	15	15	0,152	17,3
3000	315	118	35	90	130	15	15	0,441	30,7
2400	400	150	38	100	145	17,5	17,5	1,244	55,2
1900	500	190	58	110	160	20	20	3,57	95,0
1350	630	236	60	120	180	25	25	10,22	179,1
1350	710	265	80	135	200	30	30	18,41	261,4

- 1) material: GE 200 (Standard), S355J2G3 on request
- 2) use at higher speeds on request
- 3) finish bore size according to DIN EN ISO 286-1 H7, keyway according to DIN 6885-1 JS9, balancing quality G 6,3 according to DIN ISO 1940-1 other diameters and fits on request
- 4) data for D4 max