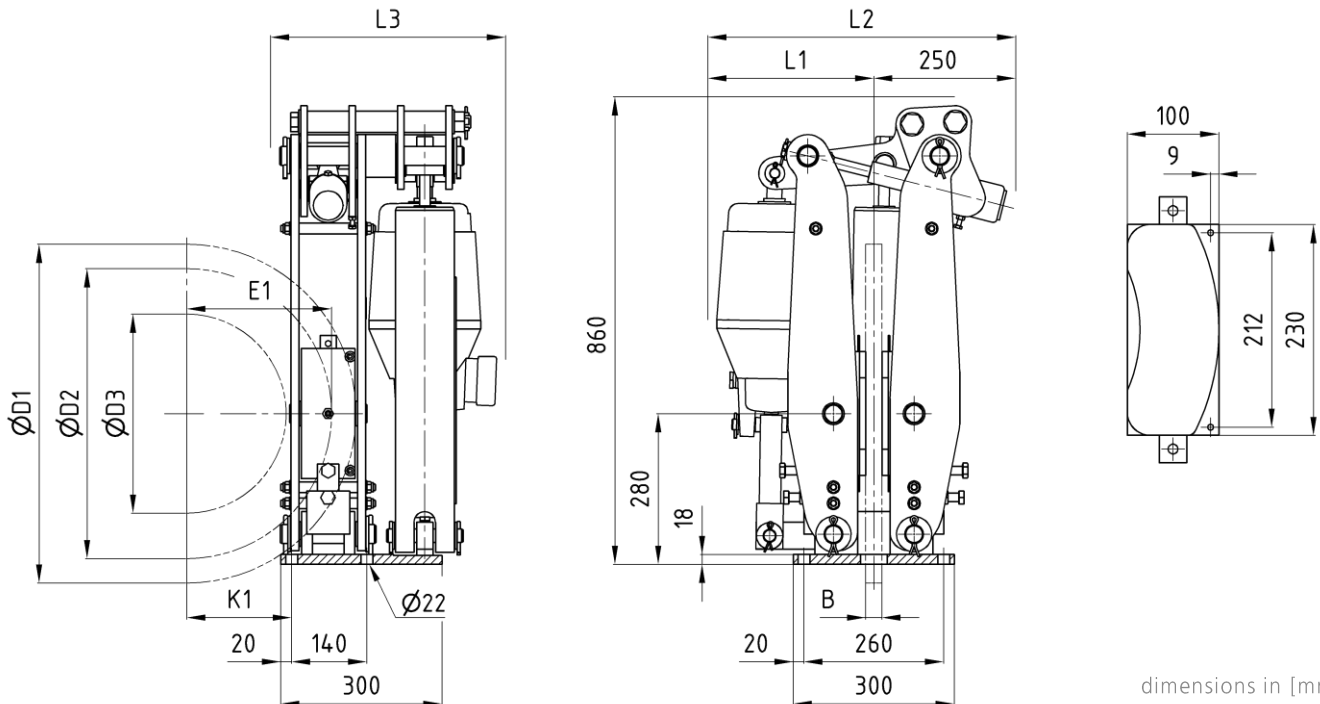

Disc brake RST 2

dimensions and technical data

 edition 06/2022 | EN
 page 1 / 1

 dimensions in [mm]
 right hand design

Order example: RST 2 80/6 – D1 x B

left hand design laterally reversed at brake disc

Technical data

Estimated weight 130 kg ²⁾				Thruster size							
				50/6		80/6		121/6		201/6	
Brake disc dimensions [mm]				M _B [Nm] μ = 0,4 ¹⁾							
ØD1	ØD2	ØD3	K1	min	max	min	max	min	max	min	max
400	309	140	80	230	900	380	1500	580	2300	900	3600
450	359	190	105	250	1000	430	1700	650	2600	1050	4200
500	409	240	130	300	1200	480	1900	750	3000	1200	4800
560	469	300	160	350	1400	580	2300	880	3500	1380	5500
630	539	370	195	400	1600	680	2700	1030	4100	1600	6400
710	619	450	235	470	1900	780	3100	1180	4700	1830	7300
800	709	540	280	550	2200	880	3500	1350	5400	2080	8300
900	809	640	330	630	2500	1000	4000	1530	6100	2380	9500
				L1 = 340 L2 = 590 L3 = 440				L1 = 350 L2 = 600 L3 = 430			

Brake disc diameter ØD1	max. 900 mm
Friction diameter ØD2	D1 - 91 mm
Maximum hub diameter ØD4	D1 - 260 mm
Thickness brake disc B	min. 20 mm
Center brake disc / brake pad E1	K1 + 68

- Available with sensor for monitoring brake open / closed position
- Available with sensor for monitoring brake pad wear
- Available in low temperature or high temperature version
- Available with brake cover made from aluminium or stainless steel

1) Friction value can change due to various operation conditions like circumferential speed, contact pressure, thermal load, material of the brake disc and environmental influences. This should be taken in consideration when calculating the brake.
 2) without thruster, without accessories

subject to change without notice