

Disc brake SST 10

dimensions and technical data

edition 06/2022 | EN
page 1 / 1

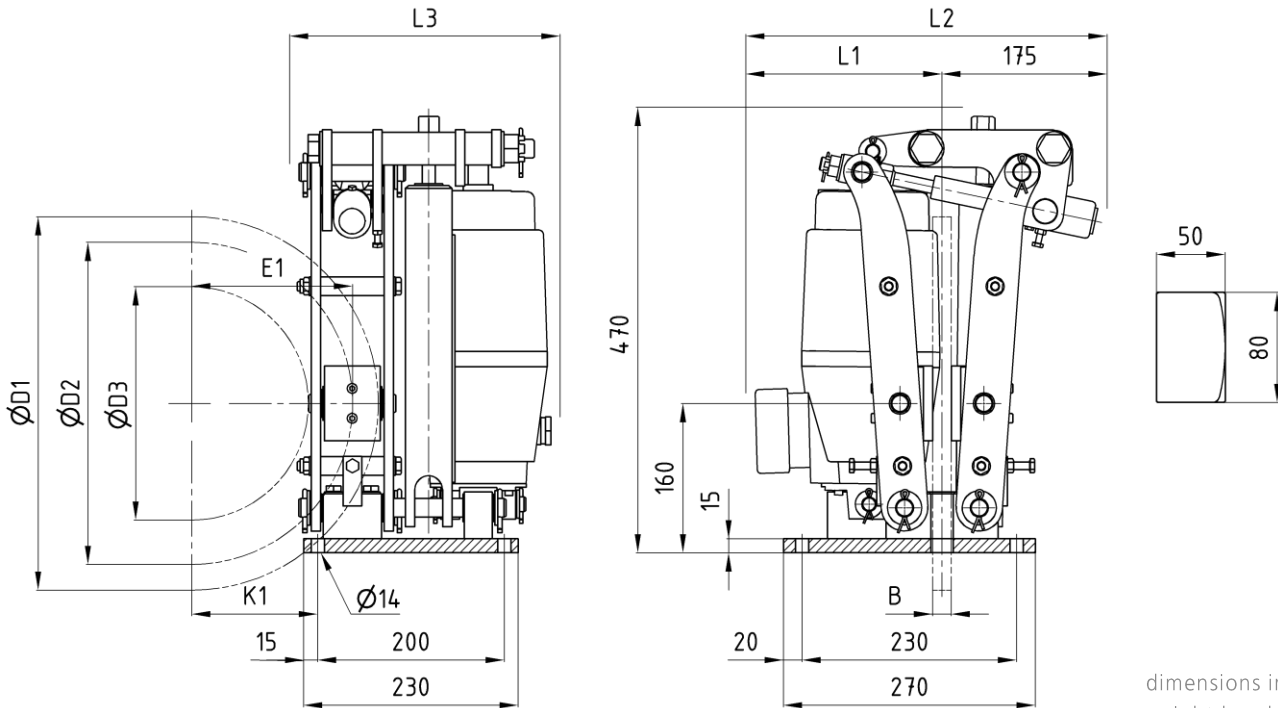

dimensions in [mm]
right hand design

Order example: SST 10 30/5 – D1 x B

left hand design laterally reversed at brake disc

Technical data

Estimated weight 30 kg ²⁾				Thruster size					
				12/4		23/5		30/5	
Brake disc dimensions [mm]				M _B [Nm] μ = 0,4 ¹⁾					
ØD1	ØD2	ØD3	K1	min	max	min	max	min	max
250	195	100	61	30	120	60	230	75	300
280	225	130	75	35	140	70	270	90	350
315	260	165	93	40	160	75	300	100	400
355	300	205	113	45	180	90	350	115	450
400	345	250	135	55	210	100	400	130	520
450	395	300	160	60	240	115	450	150	600
500	445	350	185	70	270	125	500	170	680
				L1 = 140 L2 = 315 L3 = 310		L1 = 175 L2 = 350 L3 = 365		L1 = 205 L2 = 380 L3 = 280	

Brake disc diameter ØD1	max. 500 mm
Friction diameter ØD2	D1 - 55 mm
Maximum hub diameter ØD4	D1 - 150 mm
Thickness brake disc B	min. 20 mm
Center brake disc / brake pad E1	K1 + 37

- Available with sensor for monitoring brake open / closed position
- Available with sensor for monitoring brake pad wear
- Available in low temperature or high temperature version
- Available with brake cover made from aluminium or stainless steel

1) Friction value can change due to various operation conditions like circumferential speed, contact pressure, thermal load, material of the brake disc and environmental influences. This should be taken in consideration when calculating the brake.
2) without thruster, without accessories

subject to change without notice