

Wheel body

according to DIN 15093

edition 06/2022 | EN
page 1 / 1

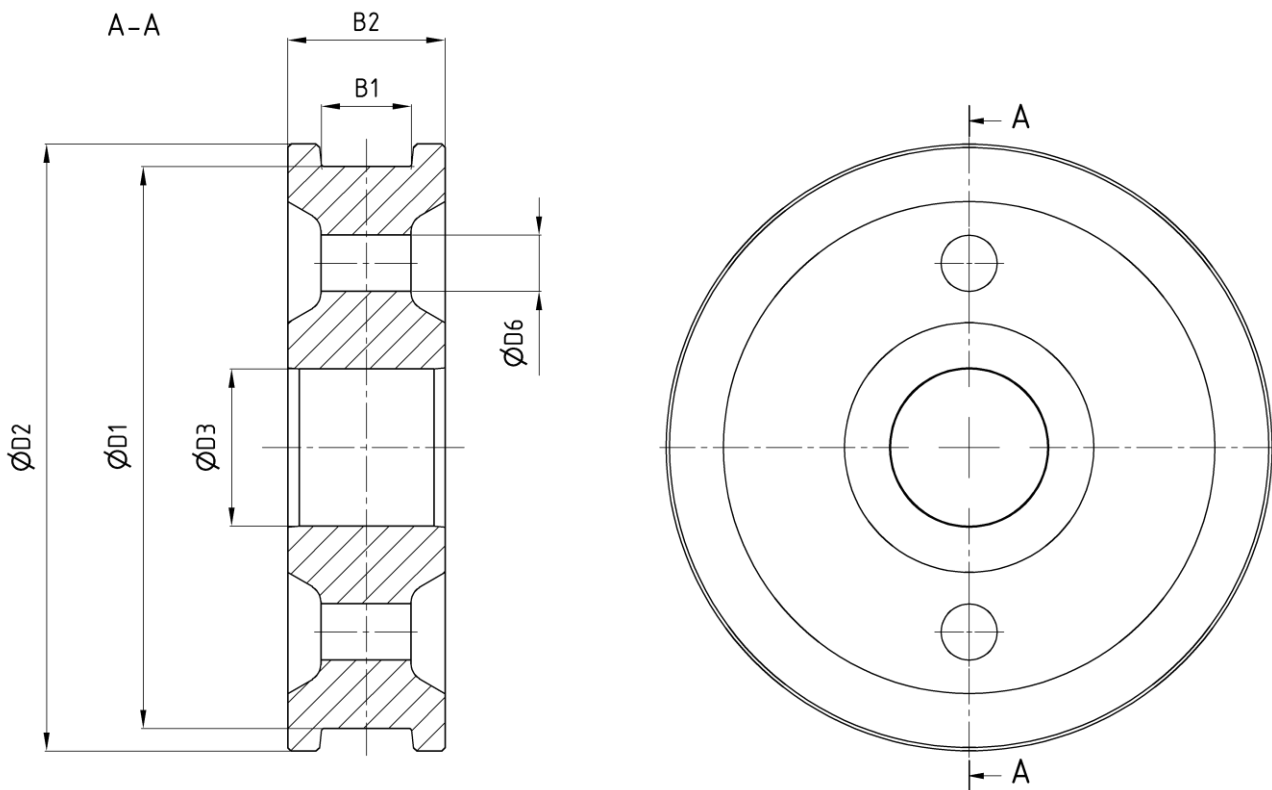

Order example: Wheel body DIN 15093 - BHKE - D1 x B1

dimensions in [mm]

Data

D1	B1		D2	B2	D3	D7	m [kg]
	min	max					
315	55	65	350	110	120	30	70
400	65	90	440	140	130	30	135
500	65	90	540	140	140	40	190
630	75	110	680	160	180	40	350
710	95	160	760	210	190	40	510
800	95	160	850	210	200	40	620

Design	
B	wide wheel
H	with wheel flange
G	without wheel flange
K	without wheel rim
E	without oilpress fit
D	with oilpress fit

- Wheel made from 42CrMo4 + QT
- maximum tensile strength: 950 - 1050 N/mm² (280 HV / 29 HRC)
- optional: Surface hardening of the running surface and the flange (530 HV / 51 HRC)
- Corrosion protection:
Synthetic resin primer 40 µm thick
mechanically machined surfaces are coated with Tectyl 506-EH