

Design A

# Non-driven wheel

according to SHN 3302/03

edition 06/2022 | EN  
page 1 / 2

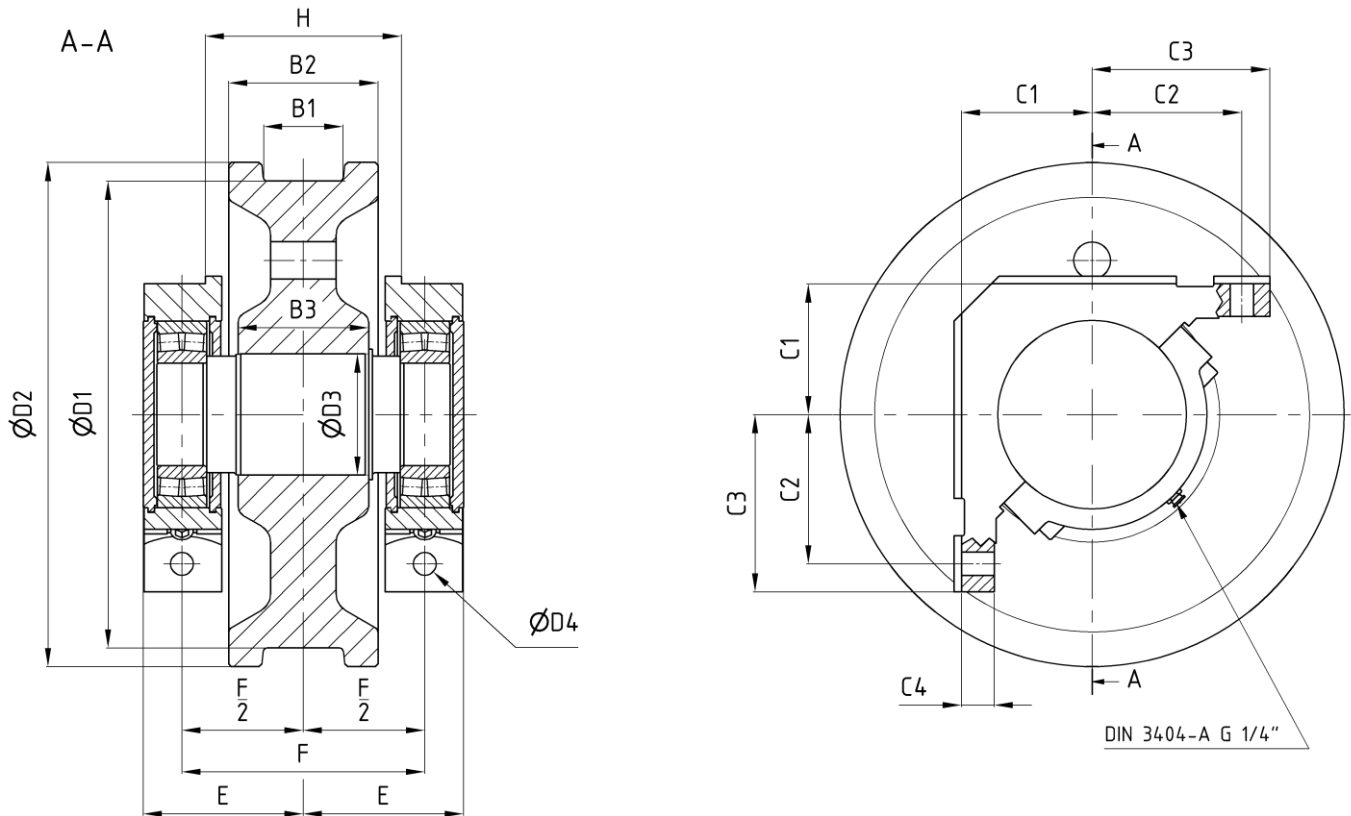

Order example: A - D1 x B1

dimensions in [mm]

### Technical data

D1	B1		D2	D3	B2	B3	E	F	H	C1	C2	C3	C4	D4	Bearing DIN 635	m [kg]
	min	max														
250	40	70	280	80	95	95	126,5	200	160	80	90	110	20	17	222 12	62
315	50	90	350	110	130	110	164,0	240	185	120	135	160	30	21	223 16	151
400	60	120	440	120	160	140	163,0	250	205	125	145	170	32	21	222 20	198
500	60	120	540	130	160	140	171,5	260	210	140	160	190	35	25	222 22	276
630	70	130	680	160	180	160	198,5	300	240	155	190	225	40	31	222 26	472
710	100	160	760	170	210	210	216,0	330	265	165	200	235	45	31	222 28	645
800	100	160	850	180	210	210	232,5	350	285	180	210	245	48	31	222 30	847

- Shaft and wheel made from 42CrMo4 + QT
- maximum tensile strength: 950 - 1050 N/mm<sup>2</sup>
- (280 HV / 29 HRC)
- optional: Surface hardening of the running surface and the flange
- (530 HV / 51 HRC)
- drive shaft - wheel / axle - wheel connection executed as interference fit
- Corner bearing strips are must be purchased separately
- Corner bearings must be filled with lubricant after installation
- Lubricant recommendation:  
Lithium / Calcium-soap grease with specification K2K-30 according to DIN 51825

Änderungen vorbehalten

Design D

# Driven wheel

according to SHN 3302/03

edition 06/2022 | EN  
page 2 / 2

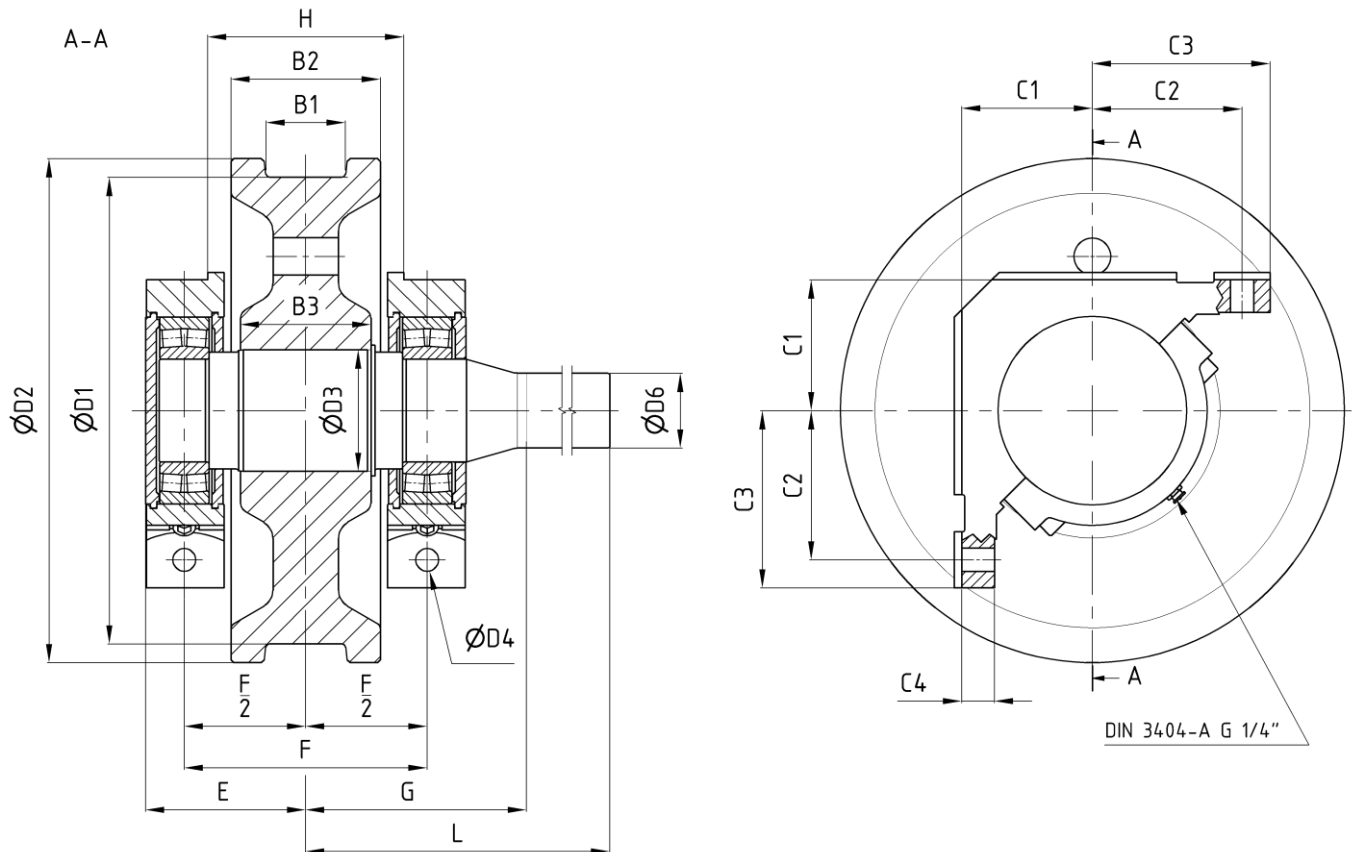

Order example: D - D1 x B1 - D6 - L

dimensions in [mm]

**Technical data**

D1	B1		G	D2	D3	B2	B3	E	F	H	C1	C2	C3	C4	D4	Bearing DIN 635	m [kg]
	min	max															
250	40	70	182	280	80	95	95	126,5	200	160	80	90	110	20	17	222 12	70
315	50	90	225	350	110	130	110	164,0	240	185	120	135	160	30	21	223 16	160
400	60	120	235	440	120	160	140	163,0	250	205	125	145	170	32	21	222 20	215
500	60	120	235	540	130	160	140	171,5	260	210	140	160	190	35	25	222 22	300
630	70	130	260	680	160	180	160	198,5	300	240	155	190	225	40	31	222 26	510
710	100	160	290	760	170	210	210	216,0	330	265	165	200	235	45	31	222 28	685
800	100	160	300	850	180	210	210	232,5	350	285	180	210	245	48	31	222 30	885

- dimensions D6 and L depends on the installed gear box and must be specified with order
- drive shaft connection for all motor manufacturer on request
- further specification equal to non-driven wheel